



RIANT WHEEL

Design & Made in Taiwan

CATALOG

PU solid tires, wheels, caster & the other accessories with High-Quality & Reliable

Version 2024-V2.7



We come from Taiwan.

Our company has passed the ISO 9001 certification by AFNOR, accredited by the Taiwan Accreditation Foundation (TAF).

Application on

Manual & Electric wheelchair,
Agriculture devices,
Storage transportation devices,
Cleaning devices,
Sports equipment,
Boat trailers,
Unmanned Vehicle.

Our Advantage

Fine Machining Technology
For better Smoothness of rolling
Less vibration
Abrasion Resistance
Better durability
Experienced Skills
Stability of quality
Uniformity or production

Reliability Test



OUR SERVICE

Your Trustworthy Partner from Taiwan.

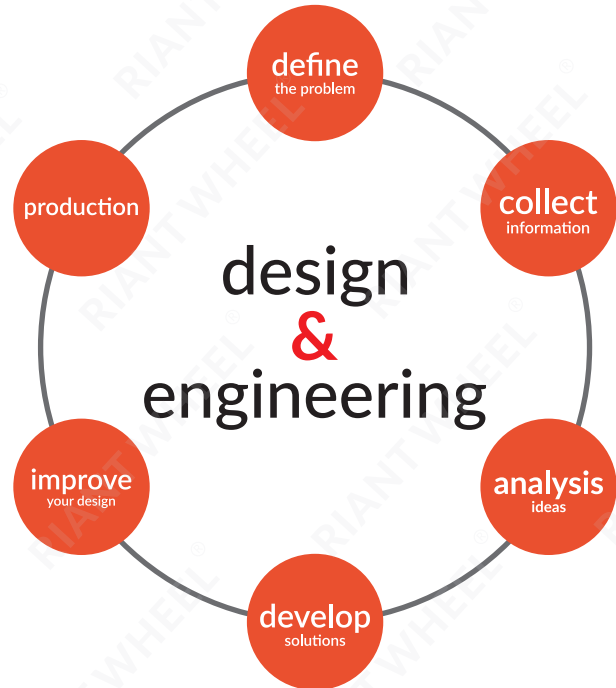

Plastic Rubber & Silicon

- Plastic Injection
- Rubber / Silicon Forming



Metal Manufacture

- Die Casting for Aluminum & Zinc
- NTC & Stamping for Steel
- CNC Machining (3~5-axis machining)
- MIM

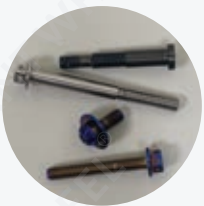

Titanium 64 Processing & Finish

- Ti64 - Machining
- Colour-Anodising for Titanium Alloy



Metal Surface Special Treatment

- Electroless Nickel Plating with Dispersed PTFE
- Plasma Chemical Coating
- Hard Anodising for Aluminum
- Black Oxide for Stainless Steel
- Stainless Steel Mirror Polished



Polyurethane Tire with Aluminum - Soft Roll Caster Series

Concentric Improving / High Strength / Ultra Light Weight / Comfort / Precision



Model No.
PWA335U00Bx00

W335 - 3" x 1.4"

3.0"	1.4"	1.0"	0.3"(8.0mm)	688	66lb / 30kg

Rim Color Available : Silver (S) / Black(B) / Blue(L) / Red(R) / Green (G) / Gold (A) / Purple(Z)



Model No.
PWA435U00Bx00
PWA425U00Bx00

W435 - 4" x 1.4" / W425 - 4" x 1.0"

4.0"	1.4"	1.0"	0.3"(8.0mm)	608	110lb / 50kg
4.0"	1.0"	1.0"	0.3"(8.0mm)	608	110lb / 50kg

Rim Color Available : Anodize : Silver (S) / Black(B) / Blue(L) / Red(R) / Green (G) / Gold (A) / Purple (Z)
Coating : White (W)



Model No.
PWA535U00Bx00
PWA525U00Bx00

W535 - 5" x 1.4" / W525 - 5" x 1.0"

5.0"	1.4"	1.0"	0.3"(8.0mm)	608	110lb / 50kg
5.0"	1.0"	1.0"	0.3"(8.0mm)	608	110lb / 50kg

Rim Color Available : Anodize : Silver (S) / Black(B) / Blue(L) / Red(R) / Green (G) / Gold (A) / Purple (Z)
Coating : White (W)



Model No.
PWA635U00Bx00

W635 - 6" x 1.4"

6.0"	1.4"	1.0"	0.3"(8.0mm)	608	110lb / 50kg

Rim Color Available : Anodize : Silver (S) / Black(B) / Blue(L) / Red(R) / Green (G) / Gold (A) / Purple (Z)
Coating : White (W)



Polyurethane Tire with Plastic Rim Series



Model No.

PWN434U30Bx00

W434- 4" (100x35mm)

2024 NEW!



4.0" (100mm) 1.4"(35.5mm) 1.0"(25.4mm) 110lb / 50kg

Color Available

Black (B)
Blue (L)
Green (G)
Orange (T)
Red (R)
Yellow (Y)
Pink (P)
Purple (Z)
White (W)

Pantone Color

-
3005C
354C
1505C
186C
012C
806C
2592C
-



Model No.

PWN534U30Bx00

W534- 5" (125x35mm)

2024 NEW!



5.0" (125mm) 1.4"(35.5mm) 1.0"(25.4mm) 110lb / 50kg

Color Available

Black (B)
Blue (L)
Green (G)
Orange (T)
Red (R)
Yellow (Y)
Pink (P)
Purple (Z)
White (W)

Pantone Color

-
3005C
354C
1505C
186C
012C
806C
2592C
-



Model No.

PWN634U30Bx00

W634- 6" (150x35mm)

2024 NEW!



6.0" (150mm) 1.4"(35.5mm) 1.0"(25.4mm) 110lb / 50kg

Color Available

Black (B)
Blue (L)
Green (G)
Orange (T)
Red (R)
Yellow (Y)
Pink (P)
Purple (Z)
White (W)

Pantone Color

-
3005C
354C
1505C
186C
012C
806C
2592C
-



Polyurethane Tire with Plastic Rim Series



Model No.
PWN514U50BB00

W514- 5" (130x30mm) - 5 Spoke

5.0" (130mm)	1.2"(30mm)	1.6"(42mm)	0.3"(8.0mm)	608	110lb / 50kg	



Model No.
PWN614U50BB00

W614- 5" (150x30mm) - 5 Spoke

6.0" (150mm)	1.2"(30mm)	1.6"(42mm)	0.3"(8.0mm)	608	110lb / 50kg	



Model No.
PWN714U50BB00
PWN714U70BB00
PWN716U50BB00
PWN716U70BB00

W714 - 7" (185x30mm) - 5 Spoke / 7 Spoke

7.0" (185mm)	1.2"(30mm)	1.6"(40mm)	0.3"(8.0mm)	608	110lb / 50kg	
7.0" (185mm)	1.2"(30mm)	1.6"(40mm)	0.3"(8.0mm)	608	110lb / 50kg	
7.0" (185mm)	1.2"(30mm)	2.4"(60mm)	0.3"(8.0mm)	608	110lb / 50kg	
7.0" (185mm)	1.2"(30mm)	2.4"(60mm)	0.3"(8.0mm)	608	110lb / 50kg	



Model No.
PWN814U50BB00
PWN814U70BB00
PWN816U50BB00
PWN816U70BB00

W814 - 8" (200x30mm) - 5 Spoke(320g) / 7 Spoke(420g)

8.0" (200mm)	1.2"(30mm)	1.6"(40mm)	0.3"(8.0mm)	608	110lb / 50kg	
8.0" (200mm)	1.2"(30mm)	1.6"(40mm)	0.3"(8.0mm)	608	110lb / 50kg	
8.0" (200mm)	1.2"(30mm)	2.4"(60mm)	0.3"(8.0mm)	608	110lb / 50kg	
8.0" (200mm)	1.2"(30mm)	2.4"(60mm)	0.3"(8.0mm)	608	110lb / 50kg	



Polyurethane Tire with Plastic Rim Series



Model No.
PWN106U51BB00

W105- 10" (255x33mm) -Weight : 490g (±5%)



10" (255mm)



1.3"(33mm)



2.1"(54mm)



0.47"(12.0mm)



6201



110lb / 50kg



Model No.
PWN125U5ABB00
(Standard Type PU)

W125B- 12" (290x40mm) -Weight : 1,030g (±5%) / (Standard Type PU)



12" (290mm)



1.6"(40mm)



2.1"(54mm)



0.47"(12.0mm)



6201



110lb / 50kg



Model No.
PWN126U51BBB0
(Economic Type PU)

W126B- 12" (290x40mm) -Weight : 640g (±5%) / (Economic Type PU)



12" (290mm)



1.6"(40mm)



2.1"(54mm)



0.47"(12.0mm)



6201



110lb / 30kg



Model No.
PWN146U51BB00

W145- 14" (340x40mm) -Weight : 930g (±5%)



14" (340mm)



1.6"(40mm)



2.2"(55mm)



0.47"(12.0mm)



6001



110lb / 50kg



Polyurethane Tire with Plastic Rim Series



W165- 16" (384x40mm) -Weight : 1,050g (±5%)

Model No.
PWN186U51BB00



16" (384mm)



1.6"(40mm)



2.4"(58mm)



0.47"(12.0mm)



6001



110lb / 50kg



W188- 18" (451x40mm) -Weight : 1,330g (±5%)

Model No.
PWN186U51BB00



18" (451mm)



1.6"(40mm)



2.0"(50mm)



0.47"(12.0mm)



6001



110lb / 50kg



Polyurethane Tire with Plastic Rim Series



Adapt for most Rollator & Walker
W524- 5" x 0.9" (125x35mm) - 5 Spoke

Model No.

PWN524U50BV00



5.0" (125mm) 0.9"(23mm) 1.1"(27.4mm) 0.3"(8.0mm) 110lb / 50kg

Solid Casters - Small but Strong



Model No.

WS-208

WS-209

WS-211

WS-271

WS-301



2.0" /50mm

2.0" /50mm

2.1" /54mm

2.7" /68mm

3.0"/76mm



0.8" /20mm

0.9"/23mm

1.0"/24mm

1.0"/24mm

1.0"/24mm



0.25" (6.4mm)

0.3" (8mm)

0.3" (8mm)

0.3" (8mm)

0.3" (8mm)



0.9"/23.5mm

1.0"/26.0mm

0.9"/23.5mm

1.0"/24.0mm

1.0"/24.0mm



Bearing 608

Bearing 608

Bearing 608

Bearing 608

Material

Nylon

Nylon + PVC

Nylon + PU

Nylon + PVC

Nylon + PU



RIANT WHEEL®

Design & Made in Taiwan.

PU Solid Tire - Sport Series (Flat Free Tire)

High Rebound & Ultra Light Weight. (Insert Forming, Non Glued Combination.)

1. Specialized PU Material Fomular
2. Efficiency & Effectiveness
3. Suitable for Multi-Type Pavement
4. Anti-puncture

The advantages of our integrated insert forming rim & tire

- | | |
|----------------------|-------------------|
| under heavy loading | - no separate |
| under high speed | - no displacement |
| under long time used | - no deformation |

Not only lightweight,
but also strong reliability



RN6S - 6" (150x40mm) -Weight : 420g (±5%)

Model No.

PWN154B6CBB00

PWN154B5CBB00



6.0" (150mm)	1.6"(40mm)	2.4"(60mm)	0.3"(8.0mm)	608	110lb / 50kg
6.0" (150mm)	1.6"(40mm)	2.0"(51mm)	0.3"(8.0mm)	608	110lb / 50kg

Color Available : Black / Gray



RN6U - 6" (150x45mm) -Weight : 450g (±5%)

Model No.

PWN155B6CBBB0

PWN155B5CBBB0



6.0" (150mm)	1.8"(45mm)	2.4"(60mm)	0.3"(8.0mm)	608	110lb / 50kg
6.0" (150mm)	1.8"(45mm)	2.0"(51mm)	0.3"(8.0mm)	608	110lb / 50kg

Color Available : Black / Gray



PU Solid Tire - Sport Series (Flat Free Tire)



Model No.

PWN175B6CBBB0

PWN175B5CBBB0

RN7C - 7" (175x45mm) -Weight : 540 g (±5%)



7.0" (175mm)	1.8"(45mm)	2.4"(60mm)	0.3"(8.0mm)	608	110lb / 50kg
7.0" (175mm)	1.8"(45mm)	2.0"(51mm)	0.3"(8.0mm)	608	110lb / 50kg

Color Available : Black / Gray



Model No.

PWN174B6CBB00

PWN174B5CBB00

RN7S - 7" (175x45mm) -Weight : 520g (±5%)



7.0" (175mm)	1.8"(45mm)	2.4"(60mm)	0.3"(8.0mm)	608	110lb / 50kg
7.0" (175mm)	1.8"(45mm)	2.0"(51mm)	0.3"(8.0mm)	608	110lb / 50kg

Color Available : Black / Gray



Model No.

PWN206A4EBB00

PWN206B4EBB00

PWN206B6CBB00

PWN206D4EBB00

PWN206E4EBB00

RN8U - 8" (200x60mm) -Weight : 820(±5%)



8.0" (200mm)	2.4"(60mm)	1.6"(40mm) (Eccentric)	-	Quick Release 19mm	110lb / 50kg
8.0" (200mm)	2.4"(60mm)	1.6"(40mm) (Eccentric)	0.5"(12.0mm)	6201	110lb / 50kg
8.0" (200mm)	2.4"(60mm)	2.0"(60mm) (Centric)	0.5"(12.0mm)	6201	110lb / 50kg
8.0" (200mm)	2.4"(60mm)	1.6"(40mm) (Eccentric/with cap)	-	Quick Release 19mm	110lb / 50kg
8.0" (200mm)	2.4"(60mm)	1.6"(40mm) (Eccentric/with cap)	0.5"(12.0mm)	6201	110lb / 50kg

Tyre Color Available : Black / Gray



Model No.

PWN286A4EBB00

PWN286B4EBB00

PWN286B6CBB00

RN - 2.8/2.5 - 4" -Weight : 985 g (±5%)



8.6" (218mm)	2.8"(72mm)	1.6"(40mm) (Eccentric)	-	Quick Release 19mm	110lb / 50kg
8.6" (218mm)	2.8"(72mm)	1.6"(40mm) (Eccentric)	0.47"(12.0mm)	6201	110lb / 50kg
8.6" (218mm)	2.8"(72mm)	2.0"(60mm) (Centric)	0.47"(12.0mm)	6201	110lb / 50kg

Color Available : Black / Gray



PU Solid Tire - Sport Series (Flat Free Tire)



Model No.
PWN205A4EBB00
PWN205B4EBB00
PWN205B6CBB00

RN8S - 8" (200x50mm) -Weight : 730g (±5%)



8.0" (200mm)	2.0"(50mm)	1.6"(40mm) (Eccentric)	-	Quick Release 19mm	110lb / 50kg
8.0" (200mm)	2.0"(50mm)	1.6"(40mm) (Eccentric)	0.47"(12.0mm)	6201	110lb / 50kg
8.0" (200mm)	2.0"(50mm)	2.0"(60mm) (Centric)	0.47"(12.0mm)	6201	110lb / 50kg

Color Available : Black / Gray



Model No.
PWN2U5A4EBBB0
PWN2U5B4EBBB0
PWN2U5B6CBB00

RN8U - 8" (200x50mm) -Weight : 820g (±5%)



8.0" (200mm)	2.0"(50mm)	1.6"(40mm) (Eccentric)	-	Quick Release 19mm	110lb / 50kg
8.0" (200mm)	2.0"(50mm)	1.6"(40mm) (Eccentric)	0.47"(12.0mm)	6201	110lb / 50kg
8.0" (200mm)	2.0"(50mm)	2.0"(60mm) (Centric)	0.47"(12.0mm)	6201	110lb / 50kg

Color Available : Black / Gray



Model No.
PWN207A4EBB00
PWN207B4EBB00
PWN207B6CBB00

RN8F - 8" (200x70mm) -Weight : 900g (±5%)



8.0" (200mm)	2.75"(70mm)	1.6"(40mm) (Eccentric)	-	Quick Release 19mm	110lb / 50kg
8.0" (200mm)	2.75"(70mm)	1.6"(40mm) (Eccentric)	0.47"(12.0mm)	6201	110lb / 50kg
8.0" (200mm)	2.75"(70mm)	2.0"(60mm) (Centric)	0.47"(12.0mm)	6201	110lb / 50kg

Color Available : Black / Gray



Model No.
PWN225A4EBB00
PWN225B4EBB00
PWN225B6CBB00

RN9U - 9" (225x55mm) -Weight : 1,020g (±5%)



9.0" (200mm)	2.2"(55mm)	1.6"(40mm) (Eccentric)	-	Quick Release 19mm	110lb / 50kg
9.0" (200mm)	2.2"(55mm)	1.6"(40mm) (Eccentric)	0.47"(12.0mm)	6201	110lb / 50kg
9.0" (200mm)	2.2"(55mm)	2.0"(60mm) (Centric)	0.47"(12.0mm)	6201	110lb / 50kg

Color Available : Black / Gray



Forks & Sub-Assembly Solutions

Excellent Smoothness in Omni-Directional Maneuver



Model No.
SF458W335fx00
SF458W435fx00 / SF458W425fx00
SF458W535fx00 / SF458W525fx00
SF458W635fx00

FK458 Series with Aluminum Soft Roll Casters

Suggest Wheels Used : 3", 4", 5", 6"
Material : Aluminum 6061 T6 / Finish : Anodizing
Fork Color Available : Silver (S) / Black(B)



Model No.
SF488W335fx00
SF488W435fx00 / SF488W425fx00
SF488W535fx00 / SF488W525fx00
SF488W635fx00

FK488 Series with Aluminum Soft Roll Casters

Suggest Wheels Used : 3", 4", 5", 6"
Material : Aluminum 6061 T6 / Finish : Anodizing
Fork Color Available : Silver (S) / Black(B)
with
Bearing : R8
Bolt : M12 / Customized available



Model No.
SFK12W335fx00
SFK12W435fx00 / SFK12W425fx00
SFK12W535fx00 / SFK12W525fx00
SFK12W635fx00

FK12 Series with Aluminum Soft Roll Casters

Suggest Wheels Used : 3", 4", 5", 6"
Material : Aluminum 6061 T6 / Finish : Anodizing
Fork Color Available : Silver (S) / Black(B)
with
Bearing : R8
Bolt : M12 / Customized available



FK64 + W514



FK64 + W514



FK74 + W714



FK84 + W814



FK86 + RN7

Nylon Fork Series with Nylon Rim PU Casters

For adapted the other size casters, Please contact with us.
Material : Fork : PA6+GF20% / Fork Color Available : Black(B)
FK64 + W514
FK64ex + W614
FK74 + W714
FK84 + W814
FK86 + RN7

Model No.
SF640W514BB00
SF64xW614BB00
SF740W714BB00
SF840W814BB00
SF860ARN7BB00



RIANT WHEEL®

Design & Made in Taiwan.

Spoke Wheels

BASIC

STROLLING

EXPLOER

RX16

RXR

Code principles :

C
↓

series:

B (with handrim)

C (no handrim)

24
↓

size:

24"

22"

20"

18"

16"

14"

26
↓

rim:

6N (P6N)

7N (P7N)

8T (P8T)

26 (P26)

DX (DX188)

D
↓

hub:

C

N

M

L

D

R

6
↓

bearing:

6 (6001)

8 (R8)

36
↓

spoke:

20

28

36

S
↓

tire tread:

0 (No tire)

S (Standard, PU)

P (Sport, PU)

A
↓

tire width:

0 (No tire)

A (1 3/8")

B (1.75")

00
↓

detail serial

STANDARD - BASIC



OVERVIEW

SPOKE 14G, 36pcs, Silver/Black
SIZE 24"
 22"
 20"

Part No.
 B2426D836SA00
 Available
 Available



RIM

TYPE P26, Single Wall
MATERIAL Aluminium
COLOR Silver/Black

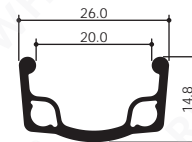

HUB

TYPE D Type
MATERIAL Aluminium
COLOR Silver/Black



R8

12.7 mm

53.0 mm

63.5 mm



TIRE

TYPE Standard
MATERIAL PU Solid tire
COLOR Black/Gray
WIDTH 1 3/8"



HANDRIM

TYPE Economic
MATERIAL Silver
COLOR Stainless Steel
MOUNTING Rivet Nuts (6H)



[Pneumatic Tire is Available. Welcome to contact us for more information.](#)



STANDARD - STROLLING



OVERVIEW

SPOKE 14G, 28pcs, Silver/Black
 SIZE 24"
 22"
 20"

Part No.
C2426B828PA00
 Available
 Available



RIM

TYPE P26, Single Wall
 MATERIAL Aluminium
 COLOR Silver/Black

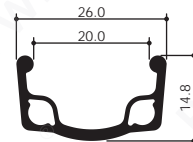

HUB

TYPE Drum Brake Hub
 MATERIAL Aluminium
 COLOR Silver



TIRE

TYPE Standard
 MATERIAL PU Solid tire
 COLOR Black/Gray
 WIDTH 1 3/8"



Pneumatic Tire is Available. Welcome to contact us for more information.



STANDARD - EXPLOER



OVERVIEW

SPOKE 14G, 20pcs, Silver/Black
 SIZE 18"
 16"
 14"

Part No.
C188TM620SB01
 Available
 Available



RIM

TYPE P8T, Single Wall
 MATERIAL Aluminium
 COLOR Silver/Black

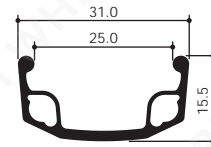

HUB

TYPE M Type
 MATERIAL Aluminium
 COLOR Silver/Black



6001



12.0 mm



53.0 mm



63.5 mm



TIRE

TYPE Standard
 MATERIAL PU Solid tire
 COLOR Black/Gray
 WIDTH 1.75"



Pneumatic Tire is Available. Welcome to contact us for more information.



2024 NEW!

SUPERIOR - RX16



OVERVIEW

SIZE 24"
22"
20"

Part No.
C24DXE8160002
Available
Available



RIM

TYPE DX188, Double Wall
MATERIAL Aluminium
COLOR Black

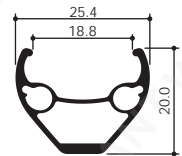

HUB

TYPE E Type
MATERIAL Aluminium
COLOR Silver/Black



R8



12.7 mm



50.8 mm



65.2 mm



SPOKE

TYPE 12G,1 cross
QTY 16 pcs
MATERIAL Steel
COLOR Black / Orange&Black / Orange&White / Multi-color customized matching



HANDRIM

MOUNTING Welded (6N)
MATERIAL Aluminium
COLOR Anodized Black



Pneumatic Tire is Available. Welcome to contact us for more information.



2024 NEW!

SUPERIOR - DA12



OVERVIEW

SIZE 24"
22"
20"

Part No.
C24D3A8120001
Available
Available



RIM

TYPE DA-230S, Double Wall
MATERIAL Aluminium
COLOR Black

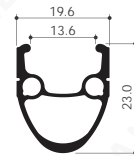

HUB

TYPE A Type
MATERIAL Aluminium
COLOR Black



R8

12.7 mm

50.8 mm

80.0 mm



SPOKE

TYPE 12G, Radial
QTY 12 pcs
MATERIAL Stainless Steel Forging
COLOR ED Black+PC Orange / Multi-color customized matching



HANDRIM

MOUNTING Welded (6N)
MATERIAL Aluminum
COLOR Anodized Black



Pneumatic Tire is Available. Welcome to contact us for more information.



Parts for Spoke Wheels

RIMS

HUBS

HANDRIMS

QUICK RELEASE

DRUM BRAKE

PU TIRE



RIMS

Code principles :

R	24	P6N	20	A	S	B	01
	↓	↓	↓	↓	↓	↓	
size:	type :	spoke holes :	material:	finish:	color:		
24"	P6N	20	A (Aluminum 6061)	S (Anodizing)	B (Black)		
22"	P7N	28		H (Hard anodizing)	S (Silver)		
20"	P8T	36					
18"	P26						
16"	188 (DX188)						
14"							

*The others, please contact us.



Part No.
R24188xxASB01

DX188 - Double Wall Aluminium Rim

Size available: 20" / 22" / 24" / 25" / 26"
Tire width : 1", 1³/₈"
Color : Black / Silver / Others
Hand Rim : Available

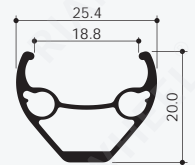

Part No.
R24D23xxASB01

DA230S - Double Wall Aluminium Rim

Size available: 23" / 24"
Tire width : 1", 1³/₈"
Color : Black / Silver / Others
Hand Rim : Available

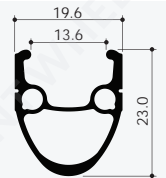

2024 NEW!



Part No.
R24P26xxASB01

P26 - Single Wall Aluminium Rim

Size available: 14" / 16" / 18" / 20" / 22" / 24" / 25" / 26"
Tire width : 1", 1³/₈"
Color : Black / Silver / Others
Hand Rim : Available

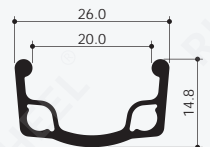

Part No.
R24P8TxxASB01

P8T - Single Wall Aluminium Rim

Size available: 14" / 16" / 18" / 20" / 22" / 24"
Tire width : 1.75"~2.125"
Color : Black / Silver / Others
Hand Rim : Available

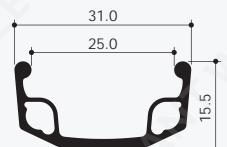

HUBS

Code principles :

R	C	6	20	50	41	A	S	S	0
	↓	↓	↓	↓	↓	↓	↓	↓	
	type:		spoke holes:			material:	finish:	color:	
C		6 (6001)	20	50 (50.0)	41 (41.0)	A (Aluminum 6061)	S (Anodizing)	S (Silver)	
M		8 (R8)	28	63 (63.5)	53 (53.0)	C (A356+SPHC)	H (Hard anodizing)	B (Black)	
N			36	66 (66.0)	43 (43.2)				
L				79 (79.0)	48 (48.5)				
D									
R									
E									

*All sizes adjustable



Part No.
RC6xx5041ASSO
RC8xx5041ASSO

Aluminium Hub - C type

Material : Aluminium 6061-T6

Color : Black / Silver / Others

Spoke Holes : 20/28/36



6001
R8



12.0 mm
12.7 mm



41.0 mm
41.0 mm



50.0 mm
50.0 mm

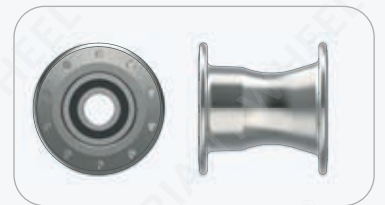

Part No.
RM6xx6353ASSO
RM8xx6353ASSO

Aluminium Hub - M type

Material : Aluminium 6061-T6

Color : Black / Silver / Others

Spoke Holes : 20/28/36



6001
R8



12.0 mm
12.7 mm



50.0 mm
50.0 mm



63.5 mm
63.5 mm

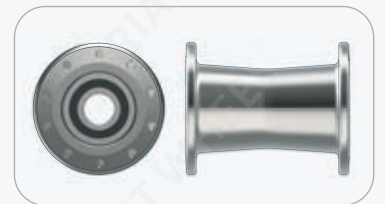

Part No.
RN6xx6353ASSO
RN8xx6353ASSO

Aluminium Hub - N type

Material : Aluminium 6061-T6

Color : Black / Silver / Others

Spoke Holes : 20/28/36



6001
R8



12.0 mm
12.7 mm



53.0 mm
53.0 mm



63.5 mm
63.5 mm

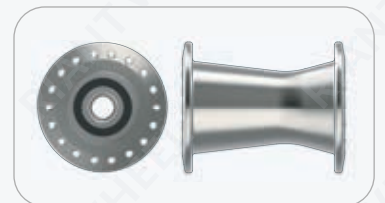



Part No.
RL6xx6353ASSO
RL8xx6353ASSO

Aluminium Hub - L type

Material : Aluminium 6061-T6
Color : Black / Silver / Others
Spoke Holes : 20/28/36



6001
R8



12.0 mm
12.7 mm



53.0 mm
53.0 mm



63.5 mm
63.5 mm

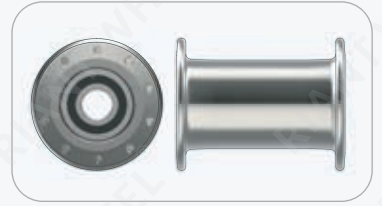

Part No.
RD6xx6353ASSO
RD8xx6353ASSO

Aluminium Hub - D type

Material : Aluminium 6061-T6
Color : Black / Silver / Others
Spoke Holes : 20/28/36



6001
R8



12.0 mm
12.7 mm



53.0 mm
53.0 mm



63.5 mm
63.5 mm

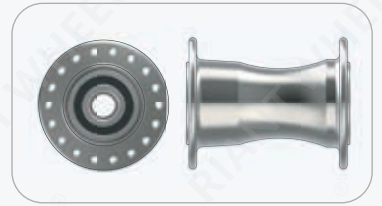

Part No.
RR6xx6648ASSO
RR8xx6648ASSO

Aluminium Hub - R type

Material : Aluminium 6061-T6
Color : Black / Silver / Others
Spoke Holes : 20/28/36



6001
R8



12.0 mm
12.7 mm



48.5 mm
48.5 mm



66.0 mm
66.0 mm



Part No.
RE6xx6648ASSO
RE8xx6648ASSO

Aluminium Hub - E type

Material : Aluminium 6061-T6
Color : Black / Silver / Others
Spoke Holes : 16/20/28/36



6001
R8



12.0 mm
12.7 mm



50.8 mm
50.8 mm



65.2 mm
65.2 mm



HANDRIMS

Code principles :

R	F	24	6	N4	A	SD	B	01
↓	↓	↓	↓	↓	↓	↓	↓	
Rim Section:	type:	pipe Φ:	Mounting Type:	material:	finish:	color:		
F: ○	24 22 20	6	N4 (Welded-4joints) N6 (Welded-6joints) H4 (Rivnuts-4joints) H6 (Rivnuts-6joints)	A (Aluminum 6061) T (Titanium) S (Stainless Steel)	SD (Anodizing) HD (Hard anodizing) NL (Original Color)	B (Black) S (Silver) C (Colorful) N (Original Steel)		

*The others, please contact us.

Hand Rim Splice Types :

Welded (N type)



Rivnuts (H type)



Part No.
RF246xxASDS01

Economic Hand Rim

Material : Aluminum 6061 Anodized
 Color : Black / Silver / Original
 Available Adapt : 24" / 22" / 20".
 Mounting Type : **N4/H4/N6/H6**
 Pipe diameter : Ø3/4" (19mm)



Part No.
RF246xxSNLN01

Stainless Steel Hand Rim

Material : Original Stainless Steel
 Color : Original
 Available Adapt : 24" / 22" / 20".
 Mounting Type : **N4/H4/N6/H6**
 Pipe diameter : Ø3/4" (19mm)





Part No.
RF246xxAHDB01

Hard Anodized Hand Rim

Material : Aluminum 6061 Hard Anodized
Color : Black / Silver / Original
Avaliable Adapt : 24" / 22" / 20"
Weight : 375g ± 1% (24")
Mounting Type : **N4/N6**
Pipe diameter : Ø3/4" (19mm)



Part No.
RF246xxAPVB01

Vinyl Coating Hand Rim

Material : Aluminum-6063 T5
Color : Black (PVC Coating)
Avaliable Adapt : 24" / 22" / 20"
Mounting Type : **N4/N6**
Pipe diameter : Ø3/4" (19mm)



Part No.
RF246xxTNLS01

Titanium Series Hand Rim

Material : Titanium
Color : Original (Anodized)
Avaliable Adapt : 24" / 22" / 20"
Weight : 318g ± 1% (24")
Mounting Type : **N4/N6**
Pipe diameter : Ø3/4" (19mm)



Part No.
RF246xxTNLC01

Titanium Series Hand Rim

Material : Titanium
Color : Colorful (PVD)
Avaliable Adapt : 24" / 22" / 20"
Weight : 318g ± 1% (24")
Mounting Type : **N4/N6**
Pipe diameter : Ø3/4" (19mm)



QUICK RELEASE

Code principles :

R	120	42	S	CS	E	S	01
	↓	↓	↓	↓	↓	↓	
	outer diameter:	length (inch) :	nut :	material:	finish:	color:	
	120 (12.0 mm)	35 (3.50 inch)	S (Standard)	CS (SAE 4130)	E (ED)	B (Black)	
	127 (12.7 mm)	37 (3.75 inch)	N (Economic)	AL (7075 Aluminum)	P (Plating)	S (Silver)	
	058 (5/8")	40 (4.00 inch)	B (Big Head)				
		42 (4.25 inch)					
		45 (4.50 inch)					
		47 (4.75 inch)					
		50 (5.00 inch)					
		52 (5.25 inch)					

*The others, please contact us.



Part No.
R12042SCSPS01

Standard

Material : SAE 4130

Color Available : Black / Chrome

Dimensions :

- 12.0mm & 12.7mm(1/2")
- 3.5", 3.75", 4.00", 4.25", 4.50", 4.75", 5.00", 5.25"
- 2 lock pins
- Details please refer our drawing



Part No.
R12742NCSPS01

Economic

Material : SAE 4130

Color Available : Black / Chrome

Dimensions :

- 12.0mm & 12.7mm(1/2")
- 3.5", 3.75", 4.00", 4.25", 4.50", 4.75", 5.00", 5.25"
- 2 lock pins
- Details please refer our drawing



Part No.
R05847BCSPS01

Big Head

Material : SAE 4130

Color Available : Black / Chrome

Dimensions :

- 5/8"
- 4.25", 4.75"
- 4 lock pins
- Details please refer our drawing





Part No.
R12045SALPS01

Ultra Light

2024 NEW!

- Material : 7075 Aluminum
- Color Available : Black / Chrome
- Dimensions :
 - 12.0mm / 12.7mm (1/2")
 - 4.00"/4.25"/4.50"
- 2 lock pins
- Details please refer our drawing

Ultra Light Quick Release: Redefining Standards with Over 50% Weight Reduction!



Ultra Light Quick Release - 12.7mm x 4.5"
50.0 g



Standard Quick Release - 12.7mm x 4.5"
110.0 g

Ultra Light Quick Release test passed:



SGS -Material Yield Tensile test:

"CNS 2111 : 1996"



SGS - Wheel/tyre assembly - Fatigue test:

"Annex A of ISO 4210-7:2014 Cycle - Safty requirements for bicycles - Part 7: Wheels and rims test methods."



SGS -Steel Ball Fatigue test:

Steel balls can withstand more than 10,000 reciprocating pneumatic cylinder.



DRUM BRAKE



Aluminum hub for Drum Brake - B type

Aluminum Hub + Steel Break Inner Wall
Foging & CNC / A356+SPHC
Color Available : Silver / ED Black
Spoke Holes : 20/28/36

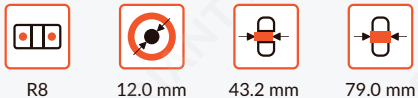

Part No.
RB8x7943C0S0



Drum Brake

Foging & CNC / ADC12
Color Available : ED Black

Part No.
R60DBA12EDB01



PU Solid Tire

Never better than PU Solid Tire you feel before.

High Rebound & Ultra Light Weight

1. Specialized PU Material Fomular
2. Efficiency & Effectiveness
3. Suitable for Multi-Type Pavement
4. Anti-puncture
5. Pneumatic Resilience Feeling

Gradient Hardess

1. Enhanced support efforts
2. Improve the omnidirection rotation flexibility
3. Light Weight & Solid



TIRE

Code principles :

R

24

size (inch) :

16
20
22
24

138

width (inch) :

183 (1 3/8 inch)
100 (1.0 inch)

SD

Tire tread :

SD (DX-S183)
SP (P-183)
DX (DX-T1)
DA (DA-T1)

PU

material :

PU

B

color:

B (Black)
G (Gray)

01

*The others, please contact us.



Part No.
R24183SDPUB01

DX-S183 (standard)

	ETRTO	Inch
Size Available :	29-540	24x1 3/8"
Tire Color Available :	Black / Gray	
Fit Rim :	DX188	

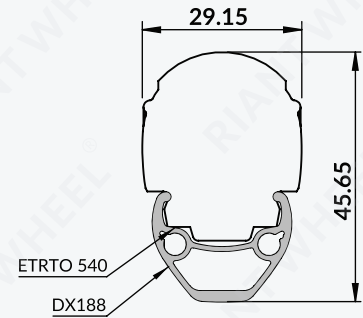

Part No.
R24183SPPUB01

P-183 (sport)

	ETRTO	Inch
Size Available :	38-540	24x1 3/8"
Tire Color Available :	Black / Gray	
Fit Rim :	P26	

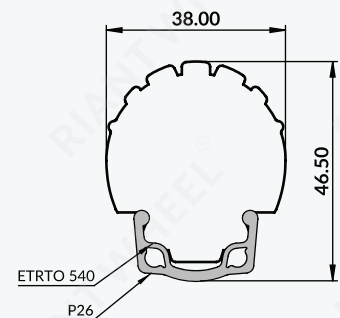

Coming Soon

Part No.
R24100DXPUB01

DX-T1

2024 NEW!

	ETRTO	Inch
Size Available :	25-540	24x1.0"
Tire Color Available :	Black / Gray	
Fit Rim :	DX188	

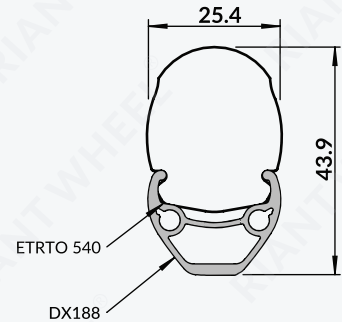

Coming Soon

Part No.
R24100DAPUB01

DA-T1

2024 NEW!

	ETRTO	Inch
Size Available :	23-540	24x1.0"
Tire Color Available :	Black / Gray	
Fit Rim :	DA-230S	

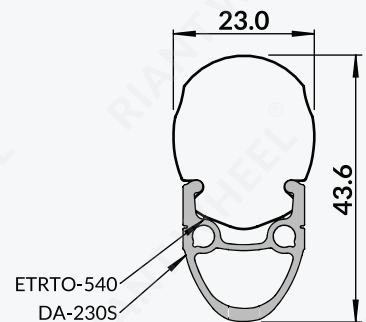

Parts & Accessories for Wheel Chair

SCISSOR WHEEL LOCK
CLAMP
FOR WHEELCHAIR USE
FOR ROLLATORS





Model No.
RBSCS00ASBA01

Scissors Wheel Lock

2024 NEW!

Material: Aluminum
Finish: Sandblasted + Anodized Black
Weight: 150g
1 Pair (Left with Right)



Model No.
PW240619250B0

Clamp - Standard

2024 NEW!

Material: 6061 T6
Finish: ED Black
Screw SPEC: M6 x L20
Fitting Tube Dimension:
- Ø19/25 mm
- Ø19/28 mm
- Ø19/32 mm



Model No.
PW240719250B1

Clamp - Teeth

2024 NEW!

Material: 6061 T6
Finish: ED Black
Fitting Tube Dimension:
- Ø19/25 mm (Screw SPEC: M5 x L16)
- Ø19/28 mm (Screw SPEC: M5 x L16)
- Ø19/30 mm (Screw SPEC: M5 x L20)
- Ø19/32 mm (Screw SPEC: M5 x L20)



Parts & Accessories for Wheel Chair



Model No.
ALA25BVE0BB01

LA25- 10" Arm Rest

Material :
ABS + Flame Retardant PVC forming (1.0mm Black cover).
EVA Inside
M5 screws Brass Nut Pre-Insert. / Screws 4 pcs



Model No.
ALA26BVE0BB01

LA26- 14" Arm Rest

Material :
ABS + Flame Retardant PVC forming (1.0mm Black cover).
EVA Inside
M5 screws Brass Nut Pre-Insert. / Screws 4 pcs



Model No.
ALA26BVE0BB01

FW10- 14" Leg Rest

Material :
ABS + Flame Retardant PVC forming (1.0mm Black cover).
M6 * 4 screws Brass Nut Insert.
Size : 242 x 153 mm.



Model No.
PHDRTPU000B00

Head Rest

Material :
PU Form molding.
With accessories
Suitable for 25mm ball-nut



Model No.
WH151100SB00

WH1511- Anti-Tipping

Material :
PA6+GF20%
Aluminum 6061
Suitable for the Wheelchair 1" & 7/8" Tube.



Parts & Accessories for Wheel Chair



Model No.
 AFWFSL195SBV0
 AFWFSL195DBV0
 AFWFSL270SBV0
 AFWFSL270DBV0

Walker Front Tube Series

Material : Aluminum tube with Nylon Rim + PVC Tire

L 195mm + 5" Single Wheel
 L 195mm + 5" Double Wheel
 L 270mm + 5" Single Wheel
 L 270mm + 5" Double Wheel

Single Wheel (S) / Double Wheel (D)
 Color Available : Black Rim (B) + Gray Tire (V)



Model No.
 PNF10B0000B00
 PNF12B0000B00
 PNF14B0000B00
 PNF16B0000B00

NF Series- Foot Pedal

Material : PA6(Nylon) + GF15%

A - (10 inch)
 A - (12 inch)
 A - (14 inch)
 A - (16 inch)



Model No.
 PMF14B0000B00
 PMF16B0000B00
 PMF18B0000B00

MF Series- Foot Pedal

Material : PA6(Nylon) + GF15%

A - (14 inch)
 A - (16 inch)
 A - (18 inch)



Model No.
 PAF03x0000B00
 PAF04x0000B00

AF Series- Foot Pedal

Material : Aluminum with Anodizing

08" - 203 x 135 mm / Thickness 4.0mm
 10" - 254 x 135 mm / Thickness 4.0mm



Model No.
 AH1SFBBRYOM00
 AH1SFBBRYOP00

RNS Series- Safety Belt

Material :

Metal Buckle - 170 cm (75")
 Plastic Buckle - 170 cm (75")



Soft Caster for Office Chair

Any surface easy, quiet & smooth rolling

1. Specialized PU Material Fomular
2. Efficiency & Effectiveness
3. Suitable for Multi-Type Pavement
4. Anti-puncture



RNOS for office chairs

Model No.
RNOCNC680900x

Material :
Nylon Fork / Rim + PVC Tire - Green(01) / Black(02)
Color Customized Available : Please contact us.

Test passed BIFMA X5.1-2017

BIFMA Test Report - tested by SGS (Taiwan)

BIFMA X5.1-2017 Clause 16.1 - Criteria :

No lost of service after 2,000 cycles over a hard surface with 3 obstacles and 98,000 cycles over a smooth hard surface without obstacles under a 122 kg (270lbs.) load on the seat...

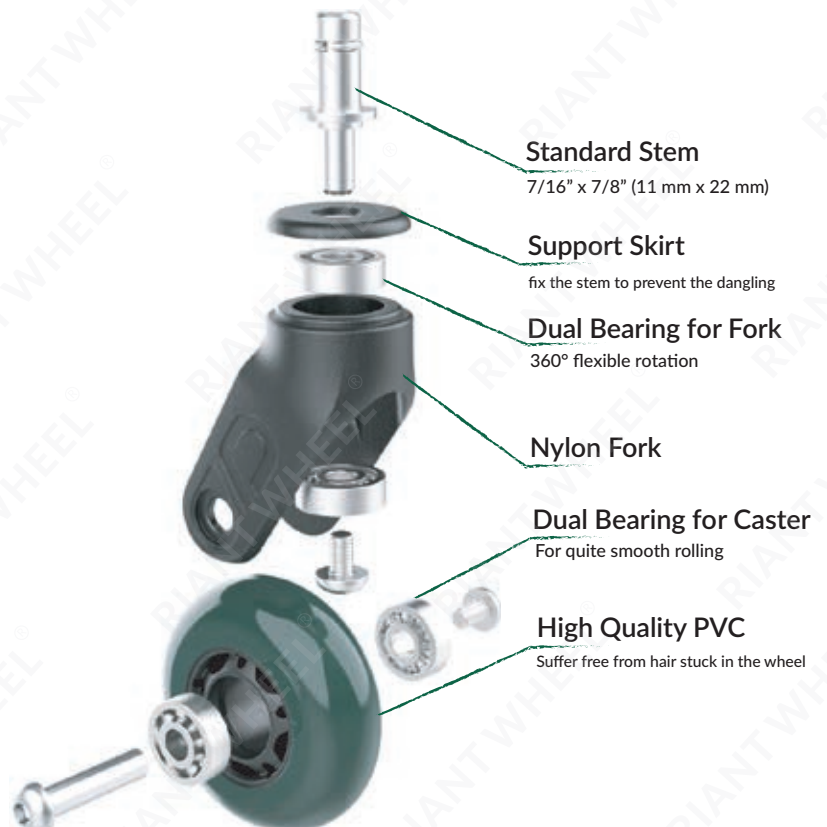

Medical Universal Silent Wheel

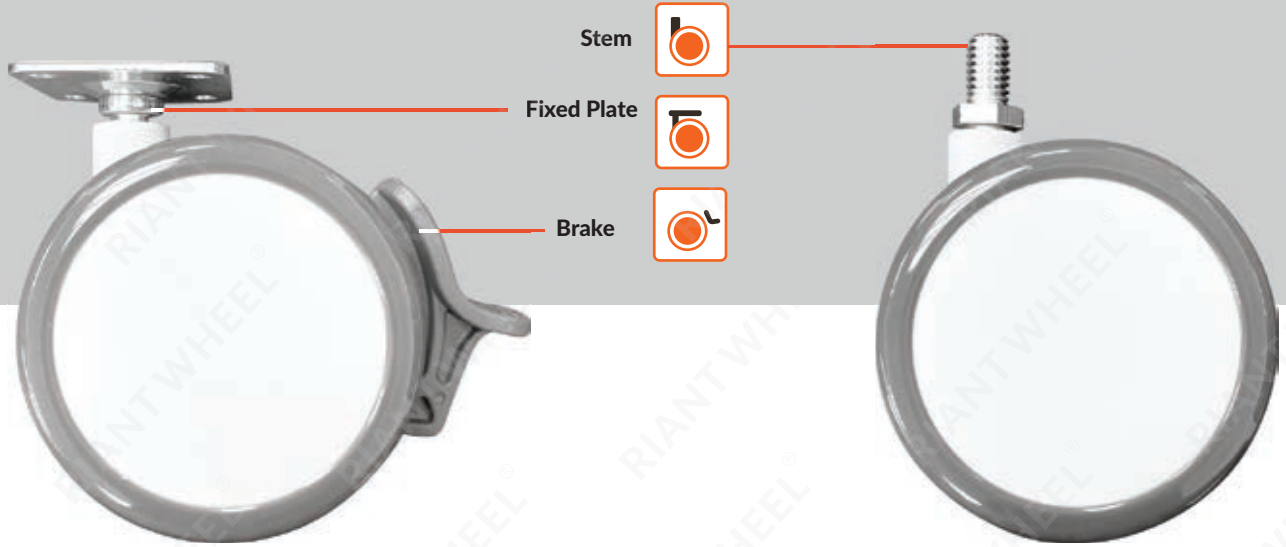

Part No.
TB022K5E19200



3" (75.0mm)



54.0mm



H.D.T

75°C



Part No.
TB022K5E19300



3" (75.0mm)



54.0mm



H.D.T

75°C



Brake



Part No.
TB022K5E19100



3" (75.0mm)



54.0mm



H.D.T

75°C



3/8"



Part No.
TB022K5E19000



3" (75.0mm)



54.0mm



H.D.T

75°C



3/8"









Brake



Medical Universal Silent Wheel









Part No.
TB022K5E24000

						
3" (75.0mm)	54.0mm	75°C	Fixed Plate	42x42mm	30.0mm	5.0mm











Part No.
TB022K5E23000

						
3" (75.0mm)	54.0mm	75°C	Fixed Plate	54x54mm	42.0mm	6.2mm











Part No.
TB022K5E24100

							
3" (75.0mm)	54.0mm	75°C	Brake	Fixed Plate	42x42mm	30.0mm	5.0mm



Part No.
TB022K5E23100

							
3" (75.0mm)	54.0mm	75°C	Brake	Fixed Plate	54x54mm	42.0mm	6.2mm



OUR QUALITY POLICY & COMMITMENT



 **SATISFIED /**
Customer-first, supreme quality & innovative service

 **TRUSTWORTHY /**
Deliver reliable & trusted services with diligence

 **INNOVATIVE /**
Consistently innovative design to meet customer needs

 **KEEP-IMPROVING /**
Continuously improving & striving for excellence



Our company has passed the ISO 9001 certification by AFNOR,
accredited by the Taiwan Accreditation Foundation (TAF).





CONTACT US

email : sales@riantwheel.com

Natural Technology Co., LTD

TEL: +886-2-8521-3009 / FAX: +886-2-8521-3801

Room B, 2F.-1, No.5, Sec. 3, New Taipei Blvd., Xinzhuang Dist., New Taipei City (24250), Taiwan

Riant Wheel® is the registered brand by Natural Technology Co., LTD
All the copy right of the pictures, drawing are owned by Natural Technology Co., LTD.
DO NOT use without legal permission.

Thanks for [Kelly Lai](#) & [Tania Chen](#) make Riant Wheel growth up by used their wilsdom & mild .

www.riantwheel.com



RIANT WHEEL®

Design & Made in Taiwan.